

CYTJ45A Hydraulic Drilling Jumbo

Equipped with 18U or HC109

Coverage area 3000X3000-5050X4500

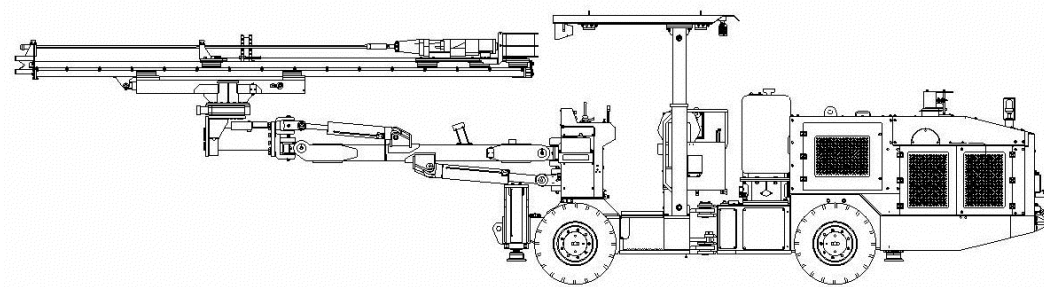

CYTJ45A Hydraulic drilling jumbo is used for underground tunneling construction in metal mine and other small and medium sized cross section tunneling work. Due to advanced all hydraulic drilling system, and anti-jamming function, the jumbo features of rapid drilling speed, and high efficiency. Compact structure and flexible tramming could greatly improve working environment and gets efficiency and qualified development.

Standard features

- **Rock drill**
Equipped with RD 18U rock drill
- **Control system**
Direct control
Anti-jamming
2 shift feeding to control impact
Auto feed back
Drilling/collaring, speed switch
- **Boom**
Double triangles suspending supporting system, intuitive movement, stable operation, accurate positioning. (All direction parallel holding)
- **Carrier**
Four-wheel drive
Yanmar, Cummins, or Deutz diesel engine
Four jacks for stable set up
- **Feeding mechanism**
Heavy-duty aluminum feed with high bending. torsional resistance, light in weight and long life
Snap-on stainless steel sleeves and polymer contact to reduce parts consumption
- **General**
Telescopic protective roof
Cable reel
Electric motor driven compressor
Electric motor driven centrifugal water pump
Working light

➤ Rock drill

Rock Drill	18U	HC109
Shank adapter	T38	T38/R38
Height over drill center	89mm	80mm
Length	1008mm	1097mm
Impact power	18KW	18.8KW
Impact rate	57HZ	47HZ
Impact pressure	180-200bar	≤135bar
Rotation system	Separate rotation	
Rotation speed	0-220r/min	0-180r/min
Rotation torque, max	1050Nm	780Nm
Lub. air consumption	7.5L/S(3bar)	5L/S(3bar)
Water consumption	40-120L/min	30-50L/min
Weight	185kg	142kg

➤ Feed

Feed	18U	HC109
Length mm	4820/5450	4820/5450
Drill steel length mm	3090/3700	3090/3700
Hole depth mm	2770/3370	2770/3370
Weight kg	530/590	470/540
Feed force kN	13	15

➤ Boom

Boom	
Feed compensation	1250mm
Parallel holding	Complete
Feed roll-over	±180°
Lifting angle	+53°/-30°
Swinging angle	±35°
Weight, boom	1535kg

➤ Air system

Air system	
Air compressor	
Air pressure monitoring	
Capacity	1m³/min
Air tank volume	25L

➤ Water system

Water pump	
Pressure monitoring	
Water pump max capacity (12bar)	4m³/h
Min water inlet pressure (bar)	2

➤ Electrical system

Rock drill	18U	HC109
Total installed power	65.5kw	
Main motor	55kw	
Voltage	380v (customized)	
Frequency	50HZ	
Cable reel diameter	1050mm	
Thermal overload protection for electric motors		
Percussion hour meter		
Digital voltmeter/amperage meter in electric cabinet		
Phase sequence indicator		
Battery		
Cable reel		
Dual controls for cable reel		

➤ Hydraulic system

Hydraulic system	
Hydraulic oil tank volume	180+90L
Filtration	10µm
Hydraulic oil level sensor	
Manual oil filling pump	
Oil temperature sensor	
Oil filter differential pressure sensor	
Water cooler	

➤ Drill rod

Drill rod	Min hole diameter
R32-B35-R38	45mm

➤ **Carrier**

Carrier	
Power (2600r/min)	55.4kw
Torque (1650r/min)	240~350Nm
Articulated steering	±35°
Rear wheel oscillation	7°
Tyres	8.25-15
Gradeability	14°
Front jack	(extendable) 2
Rear jack	2
Fuel tank volume	55L
Exhaust purification	3 stage catalyst
Battery	12V,1X200Ah
Tramming lights	4X27+4x24w
Fixed seat	
Four wheel driven	
Hydrostatic power steering	
Service brake, parking brake	
Fire extinguisher	

➤ **Side view**

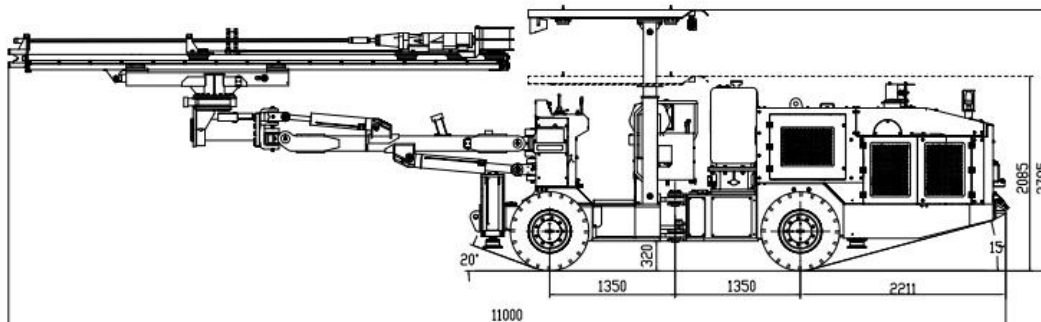

Coverage area and turning radius

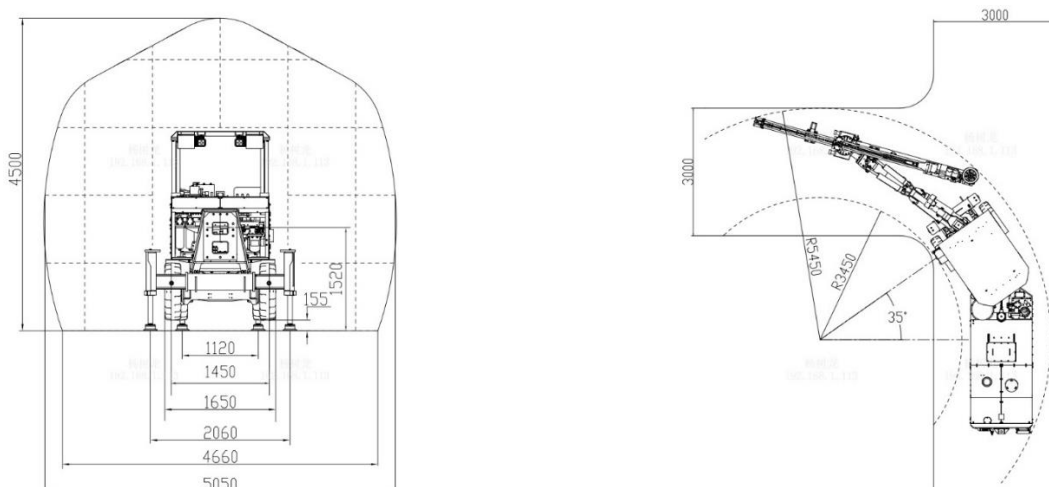

Dimensions

mm	Width (front wheel)	1650 mm
	Height (roof down)	2085 mm
	Height (roof up)	2795 mm
	Length	11000 mm
	Ground clearance	320 mm

Weight

Kg	Total weight	11500
----	--------------	-------

Cable reel size and length

Voltage	Type	Dimension mm ²	Diameter mm	Length m
380VDC	MC-0.38/0.66	3x35+1x10	40	70

Tramming speed

Km/h	On flat ground	7.2
------	----------------	-----

CYTJ45A Main Components List(18U)

No.	Description	Supplier
01	Rock drill	Epiroc
02	Main pump	Danfoss
03	Main valve	Parker
04	Electrical motor	ABB
05	Intergrated cartridge valve spool	SUN
06	Diesel engine	Deutz
07	Tramming pump	Danfoss
08	Tyres	Made in China
09	Hydraulic cylinder	Made in China (imported)seals
10	Water pump	Made in China

