

CYTJ45(B) KAMACH DRILLING JUMBO CYTJ45(B) WITH AIR SLAG REMOVING SYSTEM

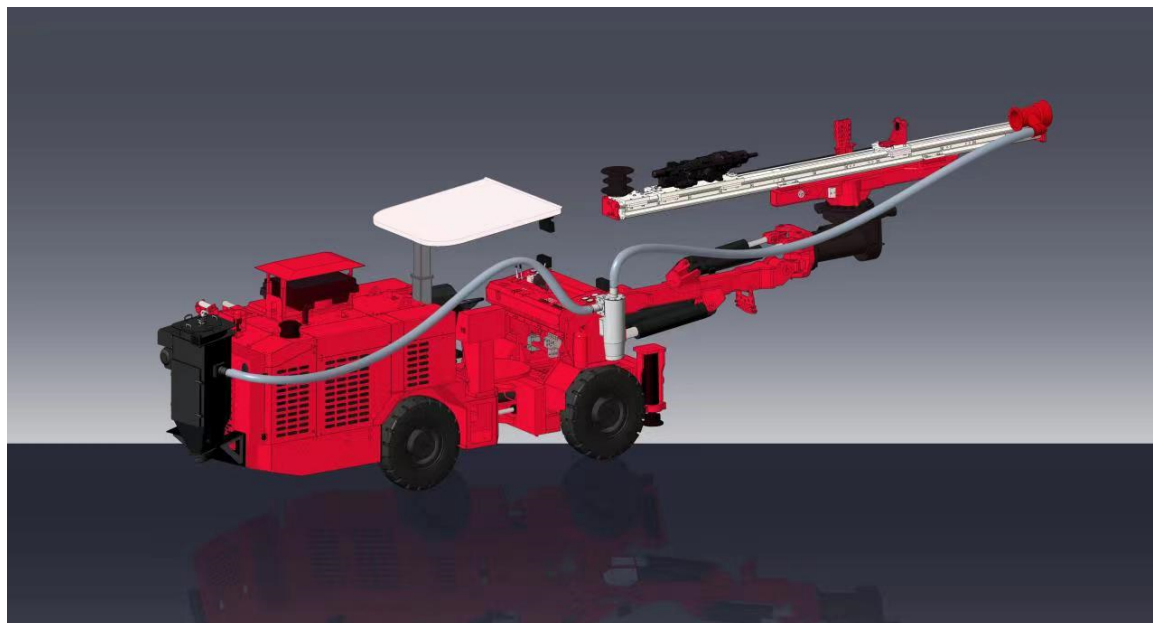

14U 凿岩机 Epiroc Perforator RD 14U

覆盖断面 (宽 mmX 高 mm) 2500X2500-3200X3200

Working face reachable (L×H): 2500mm×2500mm-3200mm×3200mm

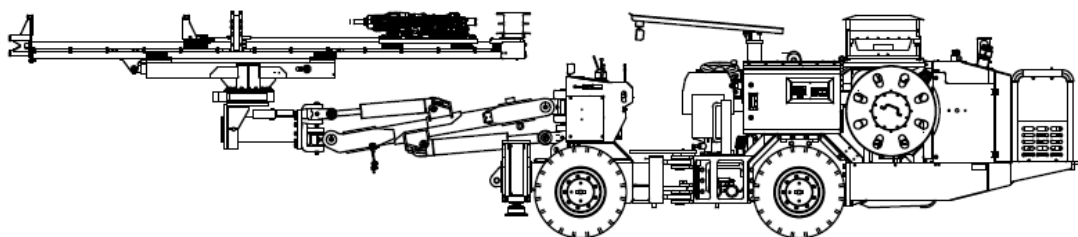

CYTJ45(B)矿用液压掘进钻车主要适用于金属矿山及其它地下工程中各种狭小的巷道、隧道的掘进施工作业，该钻车采用全液压凿岩系统，系统先进，设有防卡钎装置，凿岩速度快，工作效率高。整车结构紧凑、机动灵活移动性能好，可大幅改善工作环境，提高施工效率和施工质量。

CYTJ45(B) mining hydraulic drilling rig is mainly suitable for the excavation and construction of various narrow roadways and tunnels in metal mines and other underground projects. The drilling rig adopts a fully hydraulic rock drilling system with advanced systems and anti-jamming drill device, fast rock drilling speed and high work efficiency. The whole vehicle has a compact structure and good maneuverability and mobility, which can greatly improve the working environment, improve construction efficiency and construction quality.

标准配置 STANDARD FEATURES

凿岩机	Perforator
钻车配备 14U 凿岩机	Epiroc 14U

钻臂	Drill boom
带有双三角悬浮支撑系统，动作直观，操作运转平稳，定位准确可靠。（全方位平行保持）	Equipped with a double triangle suspension support system, the action is intuitive, the operation is stable, and the positioning is accurate and reliable. (Parallel hold in all directions)

推进机构	Feeder
采用重型铝合金推进梁，重量轻且具有较高的抗弯抗扭性能，使用寿命长	Adopt heavy-duty aluminum alloy propulsion beam, which is light in weight and has high resistance to bending and torsion, and has a long service life
推进梁外层覆盖不锈钢皮，并配有聚四氟乙烯耐磨滑块，避免金属直接接触，使推进梁零件消耗减到最小	The outer layer of the propulsion beam is covered with stainless steel skin and equipped with PTFE wear-resistant sliders to avoid direct metal contact and minimize the consumption of propulsion beam parts

控制系统	Control system
直控	Direct control
配防卡钎功能	Equipped with anti-jamming function
二档推进控制冲击	Second gear propulsion control shock

底盘	Chassis
四轮驱动	four-wheel drive
配备洋马四缸柴油发动机	Equipped with Yanmar Four -cylinder diesel engine
四只稳车支腿油缸	Four stabilize jack

通用	General
可升降顶棚	Height adjustable open cabin
电缆卷筒	Cable reel
电机驱动空气压缩机	Air compressor-ELE motor drive
工作照明灯	Working lighting
自动灭火器	Automatic Fire Suppressing System (FSS)
配置具有漏电保护功能的电源柜（含快速连接器）	Leakage protection Electric cabinet (with quick coupler)

凿岩器	Perforator	14U
品牌	Brand	Epiroc
钎尾	Shank	T38
中心高	Center height	89mm
凿岩机长	Length	1008mm
冲击功率	Impact power	14KW
冲击频率	Impact frequency	50HZ
冲击压力	Impact pressure	180bar
回转系统	Rotate system	Independent
回转速度	Rotate speed	0-220r/min
最大扭矩	Maximum torque	1050Nm
耗气量	Air consumption	7.5L/S (3bar)
耗水量	Water Consumption	40-120L/min
机重	Weight	180kg

推进器	Feeder	14U
总长	Total length	4820 mm
钎杆长	Drill rod length	3090 mm
孔深	Depth	2770 mm
重量	Weight	540 kg
推进力	Propelling force	13 kN

钻臂	Drill boom	DATA
补偿行程	Strock compensation	1250 mm
水平孔	Horizontal hole	Fully covered
滑架回转	Slide rotate	±180°
俯仰角度	Pitching angle	' + 53°/-30°
摆动角度	Swing angle	±35°
钻臂重量	Drill arm weight	1485 kg

气系统	Air system	DATA
空压机	Air compressor	
排气量	Displacement	3 m ³ /min
空气压力检测	Air pressure monitoring	

电系统	Electricity system	DATA
凿岩器	Perforator	14U
装机总功率	Total power installed	78.7kw
主电机功率	Main ELE-motor power	75 kw
电压	Voltage	380v (customerized)

频率	Frequency	50HZ
电缆卷筒直径	Cable Reel DIA.	840mm
电机热过载保护	Motor Thermal Overload Protection	
冲击计时器	Impact timer	
配电柜配数字电压电流表	Electric distribution cabinet with Digital voltage and ammeter	
相序指示器	Phase sequence indicator	
蓄电池	Battery	
电缆卷筒	Cable reel	
电缆卷筒收放控制	Cable reel retraction control	

液压系统	HYD. System	DATA
油箱容积	Fuel tank capacity	105 L
过滤精度	Filtration accuracy	10 μ m
液压油液位传感器	Hydraulic oil level sensor	
手动加油泵	manual oil pump	
油温传感器	oil temperature sensor	
液压油滤芯压差传感器	Hydraulic oil filter differential pressure sensor	

底盘	Chassis	DATA
洋马柴油发动机	Cummins Diesel engine	
功率	Engine power	75 kw/2800 rpm
扭矩	Torque	290 N·m/1650 min
车身转向角度	Steering angle	$\pm 35^{\circ}$
后车摆动角度	Rear axle oscillate	7°
轮胎	Tires	8.25-15
爬坡角度	Grade ability	14°
前支腿	Front Jack	2
后支腿	Rear jack	2
柴油箱容积	Fuel tank volume	45 Liter
尾气净化	Exhaust purifying method	TWC
蓄电池	Battery	12V,1X200Ah
行走照明	Walking lighting	2X40+4x24w
固定座椅	Fixed seat	
四轮驱动	Four-wheel drive	
液力转向器	Hydraulic steering gear	
行车制动、驻车制动	Service Brake, Parking Brake	
灭火器	Fire extinguisher	
喇叭, 行车警示灯	Horn, traffic warning lights	

钎杆规格

Drill rod specifications

规格	适用孔径 mm	适用岩石硬度
Specifications	Bore diameter (mm)	Rock hardness
R32-B35-R38	φ60-100	≤F6

外形尺寸	External dimensions	DATA
宽度	Width	1650 mm
高度 (顶棚回落)	Height (Roof down)	1850 mm
高度 (顶棚升起)	Height (Roof up)	2650 mm
总长	Length	12000 mm
离地间隙	Ground clearance	310 mm

行驶速度	Tramming speed	DATA
平坦地面	Flat horizontal roadway	4.6 km/h

重量	Machine weight	DATA
总重	Empty Weight	11 000 KGS

14U 凿岩机电缆规格和长度	14U perforator cable	DATA
电压	Voltage	380VAC
类型	Type	MC-0.38/0.66
尺寸	Cable size	3x50+1x16 mm ²
直径	Diameter	42 mm
长度	Length	40 m

钻车尺寸 JUMBO DRILL SIZE

(注: 配 3090 推进器 with 3090 feeder)

侧视图 Size-View

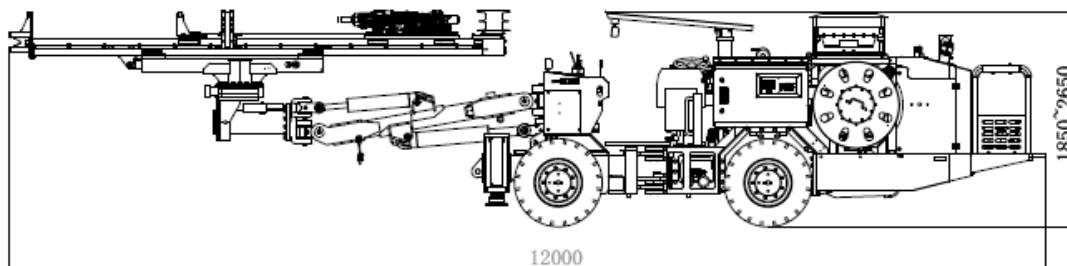

断面图转弯半径 Turning radius

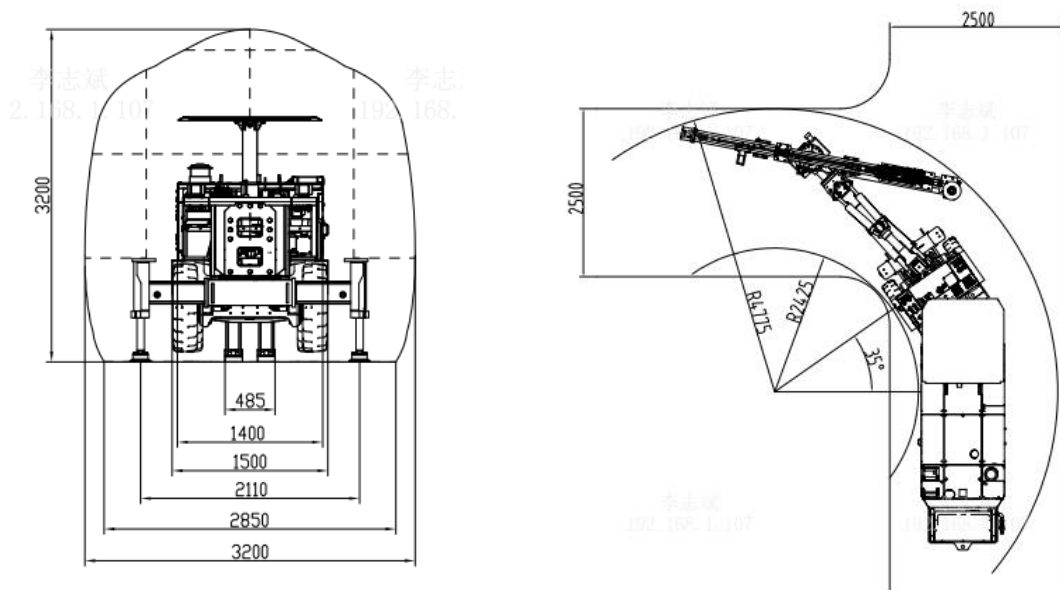

CYTJ45(B)矿用液压掘进钻车主要元件配置清单(14U)

CYTJ45(B) Mining Hydraulic Drilling Jumbo Main Components

S/N	名称	NAME	生产厂家或品牌	Brand or Maker
1	凿岩机	Perforator	安百拓	Epiroc
2	主泵	Main pump	Danfoss	Danfoss
3	主阀	Main valve	意大利 OMFB/布雷维尼	Italy OMFB/Breveni
4	电动机	ELE-motor	万高/马拉松	WEG/Marathon
5	集成插装阀芯	Integrated spool	SUN	SUN
6	柴油机	Diesel engine	康明斯	Cummins
7	行走泵	Tramming pump	Danfoss	Danfoss
8	行走减速机	Tramming reducer	力克川	Likechuan
9	液压油缸	Hydraulic oil tank	国产(进口密封)	KAMACH (Imported seal)
10	空压机	Air compressor	五洋赛德	WOYO