

KMR500 SHOTCRETE ROBOT



➤ 行业经典机型

工地应用近 20 年，成熟的定型产品
欧洲设计，德国制造标准

INDUSTRY CLASSIC MODEL

Mature and finalized products that have been used on construction sites for nearly 20 years
European design, German manufacturing standards

➤ 闭式液压系统

德国原装力士乐闭式液压系统
能耗低，泵送压力大，避免堵管
对臂架振动小，作业平顺，回弹低
脉冲低，泵送平缓

CLOSED HYDRAULIC SYSTEM

German original Rexroth closed hydraulic system
Low energy consumption, high pumping pressure, avoid pipe blockage
The vibration of the boom is small, the operation is smooth, and the rebound is low
Low pulse, smooth pumping

➤ 独特的臂架

瑞士经典三段臂结构设计，全液压伸缩，完美模仿人手结构，最灵活最精确，有效覆盖范围最大

高强度钢生产，满足作业强度，同时兼顾轻便与柔韧性

➤ 高效的混凝土泵

德国设计、德国工艺、德国标准
双活塞式，S 摆管阀切换，行程长，换向次数少，磨损低

泵送压力高达 75bar，泵送能力大

料斗设计先进，制造工艺复杂，不易积料

➤ 工程刚性底盘

专为喷射混凝土支护施工设计，尺寸紧凑，布局合理

离地间隙高，通过性好，适合隧道矿山崎岖的复杂的工况

使用寿命长，后期保养费用低

双向驾驶，驾驶室 180°旋转

非公路车桥

DANA 德纳 Spicer 系列车桥

专为喷射混凝土喷射施工定制，针对隧道矿山崎岖的工地路况

司机驾驶舒适性好，安全性高

承载力较公路车桥更高更安全

UNIQUE BOOM DESIGN

Swiss classic three-section arm structure design, fully hydraulic telescopic, perfectly imitating the human hand structure, the most flexible and precise, and the largest effective coverage

Produced from high-strength steel to meet operating strength while taking into account lightness and flexibility

EFFICIENT CONCRETE PUMP

German design, German craftsmanship, German standards

Double piston type, S swing tube valve switching, long stroke, few reversals, and low wear

Pumping pressure up to 75bar, large pumping capacity

The hopper has advanced design, complex manufacturing process and is not easy to accumulate materials.

RIGID CHASSIS FOR HEAVY INDUSTRY

Specially designed for shotcrete support construction, compact size and reasonable layout

High ground clearance and good passability, suitable for rugged and complex working conditions in tunnels and mines

Long service life and low maintenance costs

Two-way driving, driver's seat rotates 180°

OFF-HIGHWAY AXLE

DANA Spicer series axles

Specially customized for shotcrete spraying construction, targeting the rugged construction site conditions in tunnels and mines

Comfort and safety for drivers

Higher load and safer than highway axles.



DIMENSIONS

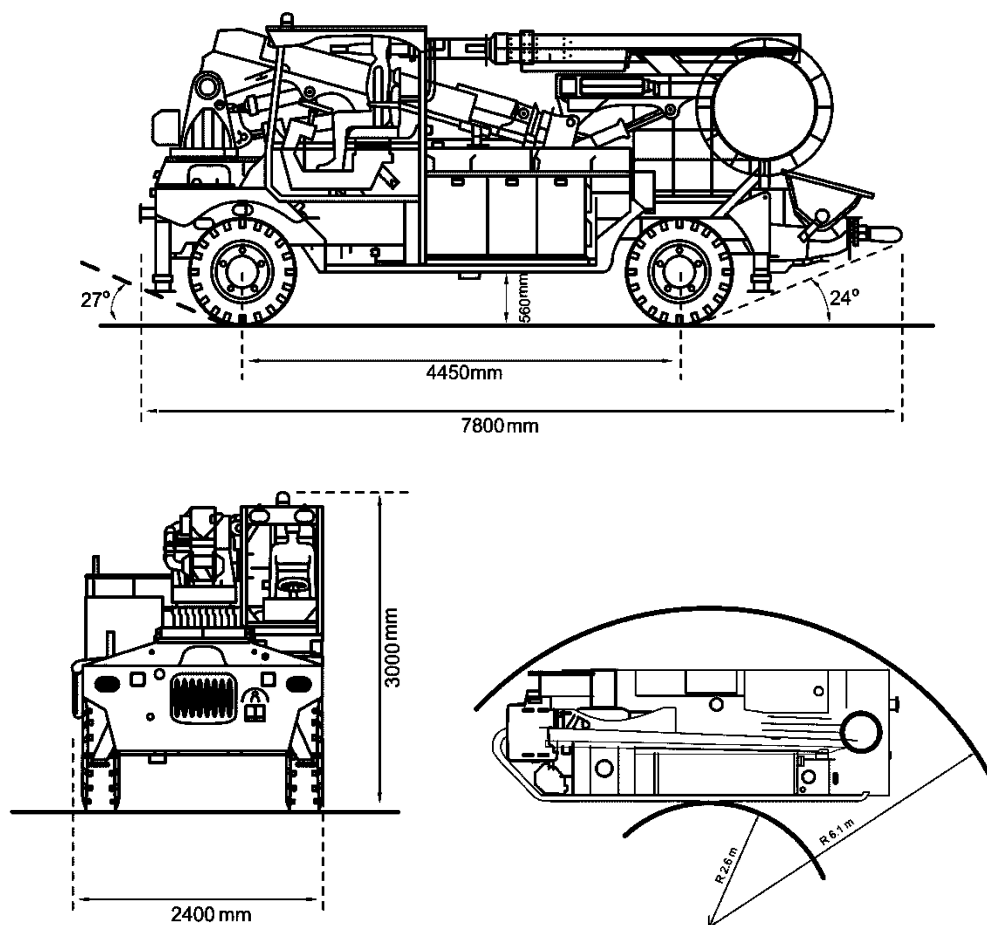

WORK RANGE

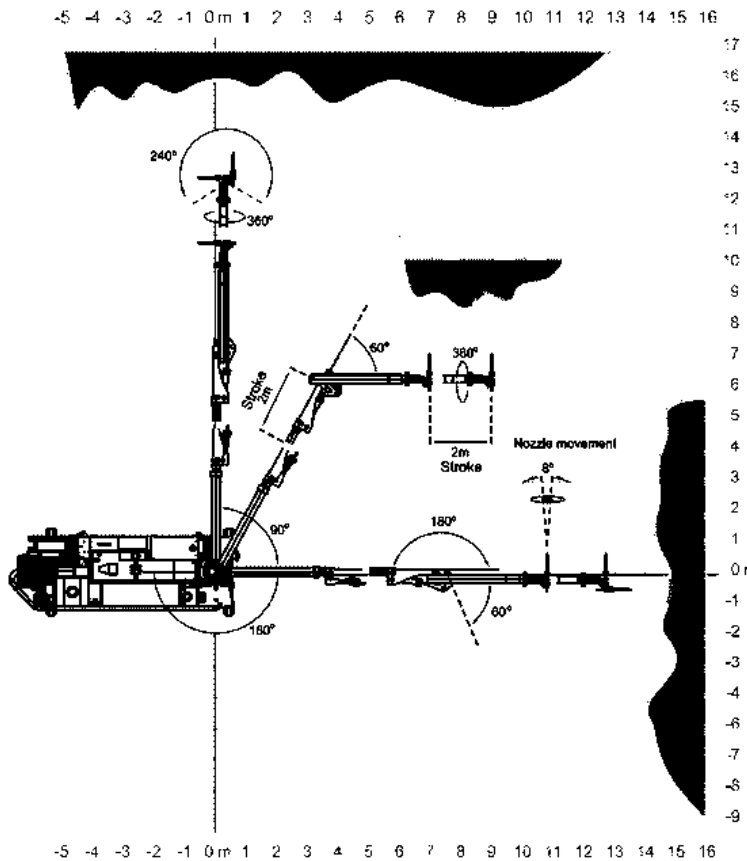
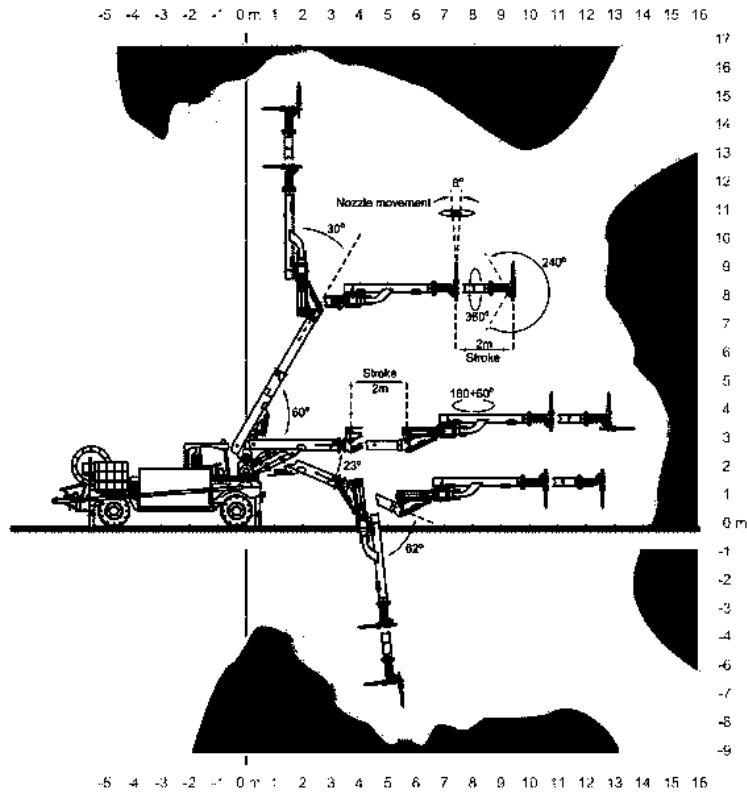

| 整机参数 Shotcrete Parameter | | |
|--------------------------------|--------------------------|--|
| 整机尺寸 | Machine size | Length 7800x Width 2400x Height 3000 mm |
| 重量 | Empty weight | 16000KG (with air compressor)/14500KG (without air compressor) |
| 底盘 Chassis | | |
| 形式 | Type | Rigid chassis, diesel engine-hydrostatic transmission, four-wheel drive, four-wheel steering, two-way driving, ROPS/FOPS safety roof cab |
| 发动机 | Engine | Diesel four-cylinder water-cooled turbocharged engine 74.9kW/2300rpm (National 3)/81kW (National 4) |
| 车桥 | Drive axle | Import DANA SPICER series off-road drive axles |
| 液动力装置 Hydraulic system | | |
| 形式 | Type | Motor-driven hydraulic power pack provides hydraulic power for spray arms, concrete pumps, outriggers and cable reel. |
| 液压油泵 | Hydraulic pump | Closed electro-hydraulic controlled plunger pump |
| 多路阀 | Multi-way valve | Load Sensing Proportional Valve Group |
| 喷射机械手 Spray Boom | | |
| 形式 | Type | Fully hydraulic telescopic and swivel spray arm |
| 喷射距离 1m 时: | Spray distance at 1m | |
| 喷射高度 | Spray height | Max.17m/Min.4m |
| 喷射宽度 | Spray width | Max.30m/Min.7.7m |
| 喷射臂动作 | Movement of boom | 9 |
| 臂架仰俯角度 | Pitch angle | Boom +60°/-23°, small arm +30°/-62° |
| 遥控器 | Remote controller | LoS remote controller |
| 喷射头 Spray nozzle | | |
| 喷嘴绕臂纵轴回转 | Nozzel axial rotate | 360° |
| 喷嘴绕臂纵轴摆动 | Nozzel horizontal rotate | 240° |
| 喷嘴刷动 | Nozzel brush | 8° declination/360° rotation |
| 混凝土喷射泵 Wet concrete spray pump | | |
| 形式 | Type | Hydraulically driven long-stroke double-piston concrete pump, automatic and quick-switching S-shaped swing pipe valve |
| 泵送能力 | Pumping capacity | 30m³/h |
| 输送压力 | Pumping pressure | 75 bar |

| 料斗 Hopper | | |
|-----------------------------------|----------------------------|---|
| 筛格 | Mesh grid | With vibrating mesh grid and emergency shutdown switch |
| 容量 | Volume | 350L |
| 喂料高度 | Feed height | 1.44m |
| 速凝剂泵 Additive | | |
| 形式 | Type | Peristaltic squeeze pump, output is synchronized with concrete pumping volume |
| 调节范围 | Work range | 30-700 L/h |
| 速凝剂箱 Additive tank | | |
| 速凝剂箱 | Additive tank | 1000L, 1 piece |
| 电缆卷筒 Cable reel | | |
| 形式 | Type | Hydraulic drive |
| 电缆电压 | Cable and Voltage | 3x380-400V/50Hz |
| 长度 | Length | 60m standard/100m optional |
| 高压清洗水泵 High pressure washing pump | | |
| 高压清洗水泵 | High pressure washing pump | Working pressure Max.150 bar/Flow rate: 15L/min |
| 空压机 Air compressor | | |
| 形式 | Type | Electric screw air compressor |
| 电机功率 | Electric motor power | 75kW |
| 工作压力 | Work pressure | 7.5bar |
| 供风量 | Air supply | 11m ³ /min |

SPECIFICATIONS MAY CHANGE ACCORDING TO DIFFERENT CUSTOMER REQUIREMENT, KAMACH HAS THE FINAL LEGAL RIGHT OF EXPLANATION.