

LWL-312A/90L Excavating and Mucking Machine

Item	Specifications
Model	LWL-312A/90L
Productivity (m <sup>3</sup> /h)	312
Machine weight (kg)	30000±5%
Turning radius (m)	<8
Ground clearance (mm)	>430
Digging height (mm)	>6800
Digging height (mm)	>6077
Excavating distance (mm)	>2700
Unloading height (mm)	>3780
Digging depth (mm)	>950
Loading height (mm)	>6800
Grade ability (°)	>22
Conveyor speed (m/s)	0.7±5%
Electric motor power (kw)	90
Travelling speed (m/s)	1.1±5%
Rated working pressure (MPa)	25
Safety valve activating pressure (MPa)	26
Working temperature (°C)	-5~+40
Dimensions (transport)	12170*2650*3150 (L*W*H)
Diesel engine for drive only	
Diesel Engine (kw)	75
Rated radius (rpm)	2200
Coolant	Air-cooled/water-cooled
Operation method	Hydraulic-control

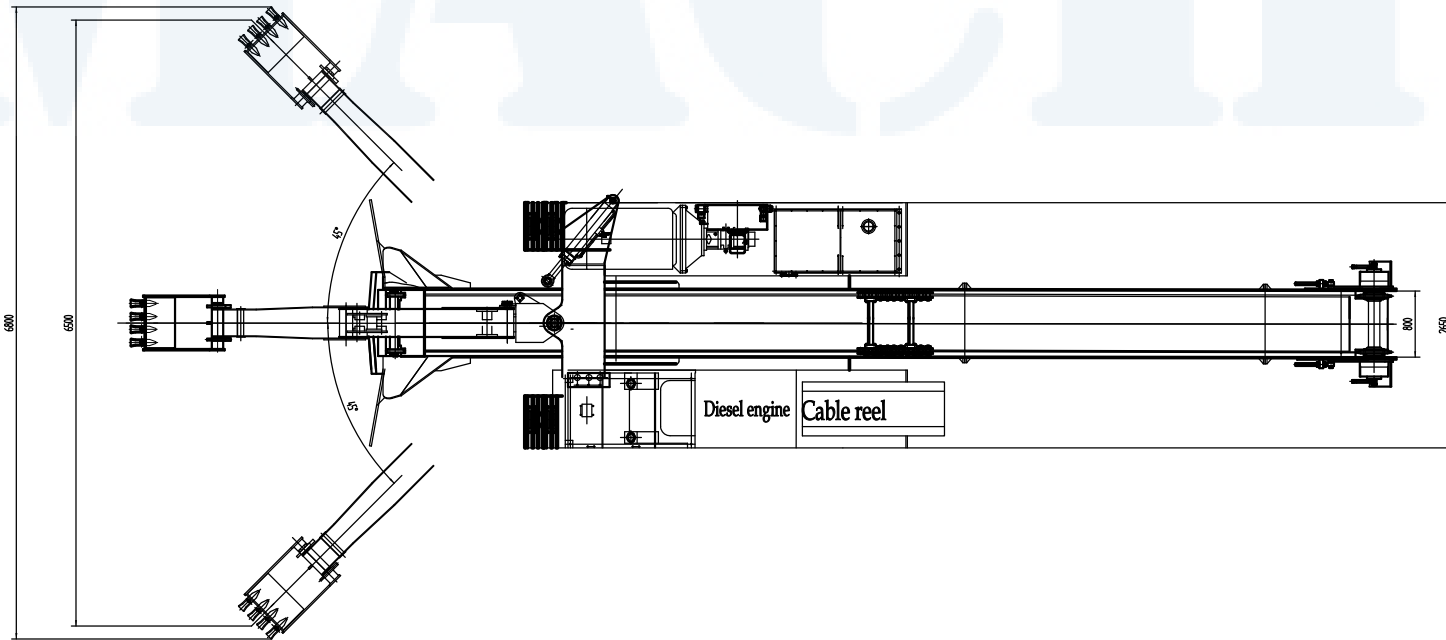

				Excavating and mucking machine		LWL-312A/90L	
						MP: +86 13907098609	
设计	校核	审核	工艺	图样标记	重量	比例	
日期	日期	日期	日期	共	页	第	页
				kamach@kamach.com			