

CYTJ45D Hydraulic face drilling jumbo



Coverage area (W mm × H mm) 2000×2000-2800×2800

CYTJ45D Hydraulic face drilling jumbo is used for underground tunneling construction in metal mine and other small and narrow cross section tunneling work. Special drilling mechanism enable it work at small tunnel of 2m×2m. Due to advanced electronic controlled hydraulic drilling system, and anti-jamming function, the jumbo features of rapid drilling speed, and high efficiency. Compact structure and flexible tramming could greatly improve working environment and gets efficiency and qualified development.

Standard features

- **Rock drill**
 - Equipped with 14U rock drill
- **Boom**
 - Equipped with imported angel sensor, stable operation, accurate positioning.
 - New boom structure, fit small cross section tunnel requirement
- **Feeding mechanism**
 - Heavy-duty aluminium feed with high bending. torsional resistance, light in weight and long life
 - Snap-on stainless steel sleeves and polymer contact to reduce parts consumption
- **Control system**
 - Electronic control
 - Anti-jamming
 - Electric proportional feeding control percussion
- **Carrier**
 - Four-wheel drive
 - Cummins 4-cylinder, stage III engine
 - Four jacks for stable set up
- **General**
 - Telescopic protective roof
 - Electric motor driven compressor
 - Electric motor driven centrifugal water pump
 - Working light

Rock drill

	14U	RC1200
Shank adapter	T38	R32
Height over drill center	89mm	90mm
Length	1008mm	572mm
Impact power	14KW	14KW
Impact rate	50HZ	100HZ
Impact pressure	180bar	180bar
Rotation system	Separate rotation	
Rotation speed	0-220r/min	0-320r/min
Rotation torque, max	1050Nm	310Nm
Lub. air consumption	7.5L/S (3bar)	4.3L/S (3bar)
Water consumption	40-120 L/min	40-80 L/min
Weight	180kg	126kg

Feed

	14U	RC1200
Length mm	4110	3460
Drill steel length mm	2475	2475
Hole depth mm	2130	2130
Weight kg	540	440
Feed force kN	13	13

➤ Boom

- Feed compensation1250mm
- Parallel holdingComplete
- Feed roll-over.....±180°
- Lifting angle.....±60°
- Swinging angle.....±35°
- Weight, boom 1400kg

➤ Air system

- Air compressor
- Air pressure monitoring
- Capacity..... 1m³/min
- Air tank volume..... 25L

➤ Water system

- Water pump
- Pressure monitoring
- Water pump max capacity (12bar) 4m³/h
- Min water inlet pressure (bar) 2

Electrical system

Total installed power	64kw
Main motor	55kw
Voltage	380v (customized)
Frequency	50HZ
Cable reel diameter	840mm
Thermal overload protection for electric motors	
Percussion hour meter	
Digital voltmeter/amperege meter in electric cabinet	

➤ Hydraulic system

- Hydraulic oil tank volume..... 100 L
- Filtration10 μ m
- Hydraulic oil level sensor
- Manual oil filling pump
- Oil temperature sensor
- Oil filter differential pressure sensor
- Water cooler

➤ Carrier

- Yuchai stage III diesel engine
- Power (2400r/min) 60 kw
- Torque (1700r/min) 320Nm
- Articulated steering.....±35°
- Rear wheel oscillation.....7°
- Tyres..... .8.25-15
- Gradeability..... 14°
- Front jack..... 2
- Rear jack..... 2
- Fuel tank volume.....55L
- Exhaust purification three way catalyst
- Battery..... 24V,2X120Ah
- Trammig lights..... 5X40+2x20w
- Fixed seat
- Four wheel driven
- Pilot steering hand lever
- Service brake, parking brake
- Fire extinguisher
- Horn, trammig warning light

Drill steel

Size	Min. hole size mm
R32-B35-R38	45 (14U)
R28-B28-R32	43 (RC1200)

Measurements (2475 feed)

Side view

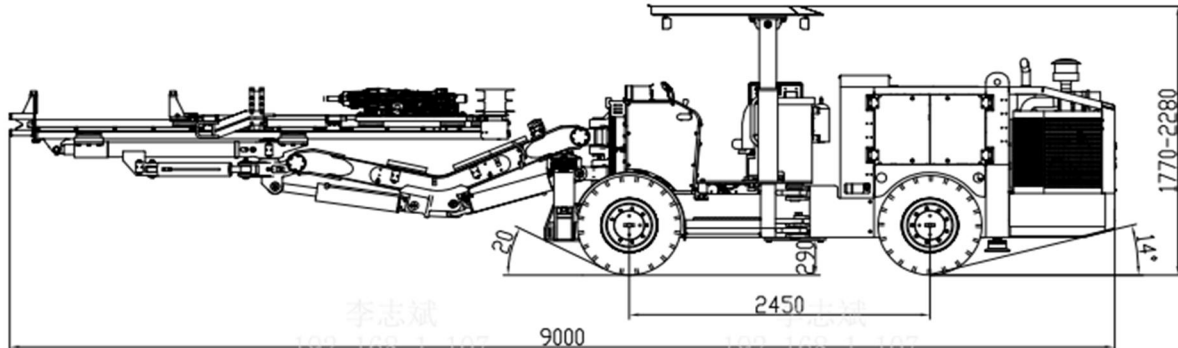

Coverage area

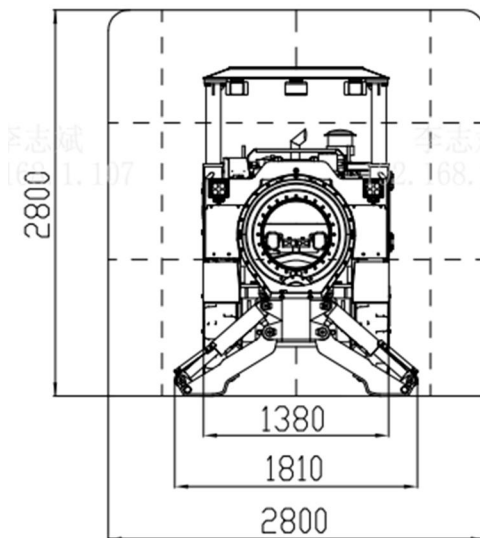

Turning radius

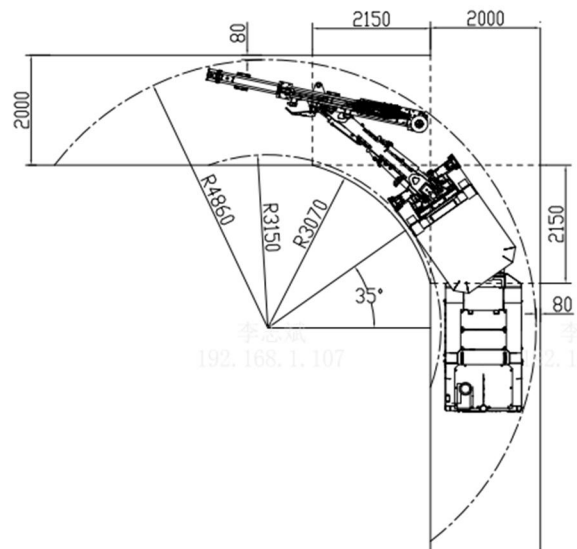

Dimensions

mm	Parameter	Value
	Width	1380
	Height (roof down)	1770
	Height (roof up)	2280
	Length	9000
	Ground clearance	290

Weight

Kg	Weight	Value
		9300

14U Cable reel size and length

Voltage	Type	Dimension mm ²
380	MC-0.38/0.66	3x35+1x10

Tramming speed

Km/h	On flat ground	Value
		3.8

Optional equipment

- Cable reel

Main Components List(14U)

No.	Description	Supplier
01	Rock drill	Epiroc
02	Main pump	Danfoss
03	Main valve	OMFB
04	Electrical motor	China Made
05	Intergrated cartridge valve spool	SUN
06	Diesel engine	Cummins
07	Tramming pump	Danfoss
08	Tyres	Made in China
09	Hydraulic cylinder	Made in China (imported)seals)
10	Water pump	Made in China

产品不断更新，如有变动不另行通知，所有配置清单以最终签订合同为准，敬请谅解。

Products would update continuously. Please kindly understand that we would not inform if changed, the final configuration will be subject to contract.

