

CYTJ45/2 FACE DRILLING JUMBO

✧ Coverage area 45 m²



Specification :

RD 18U hydraulic drifter (Epiroc)		
Shank adapter		TR38
Height over drill centre		89mm
Impact power		18 kW
Impact rate		57Hz
Hydraulic pressure		220bar
Rotation system		Separate rotation
Rotation speed		145rpm
Rotation torque, max		1050Nm
Lub. air consump. at 3bar		5 l/s
Water consumption		25L/min
Weight		185 kg

HT Series Feeds		
	HT A	HT B
Total length	5350 mm	5915 mm
Drill steel length	3700 mm	4305 mm
Hole depth	3365 mm	3930 mm
Weight, incl. drill	595 kg	620 kg
Feed force	15.0 kN	15.0 kN

Telescopic Boom	
Feed extension	1250mm
Boom extension	1250mm
Parallel holding	complete
Feed roll-over	360°
Max. lifting angle	+53° / -30°
Max. swinging angle	±35°
Weight, boom only	1850kg

Hydraulic system	
Hydraulic pumps	2 separate units, each one for one boom, Pumps unloaded at start
System pressure, max	150~230 bar
Hydraulic oil tank, volume max/min	200 L
Oil temperature gauge on oil tank	
Water cooled oil filtration	20µm
Mineral hydraulic oil	
Two operator control panels	

Air system	
Compressor capacity, max at 7 bar	1.2 m³/min
Air pressure gauge	

Water system	
water booster pump	CDL8-16
Water booster pump max capacity at 13.5 bar	100 l/min
Min water inlet pressure	2 bar

PowerTrain	
Cummins diesel engine	
Power rating at 2 300 rpm	74 kw
Torque at 1 500 rpm	340 Nm

Carrier

Articulated steering angle	± 40°
Fixed seat for tramming	
Four-wheel drive	
Hydrostatic power steering system	
Front axle	KAMACH
Rear axle oscillate	KAMACH, ±8°

Electrical system

Total installed power	125 kW
Main motors	2 x 55 kW
Voltage	380v (customized)
Frequency	50Hz/60Hz

Dimensions and Weight

Width	2100mm
Height with cabin	3073mm
Height roof up/down	3073/2473mm
Length with HTB feeds	12617mm
Ground clearance	275mm
Total	22000 kg

Side view

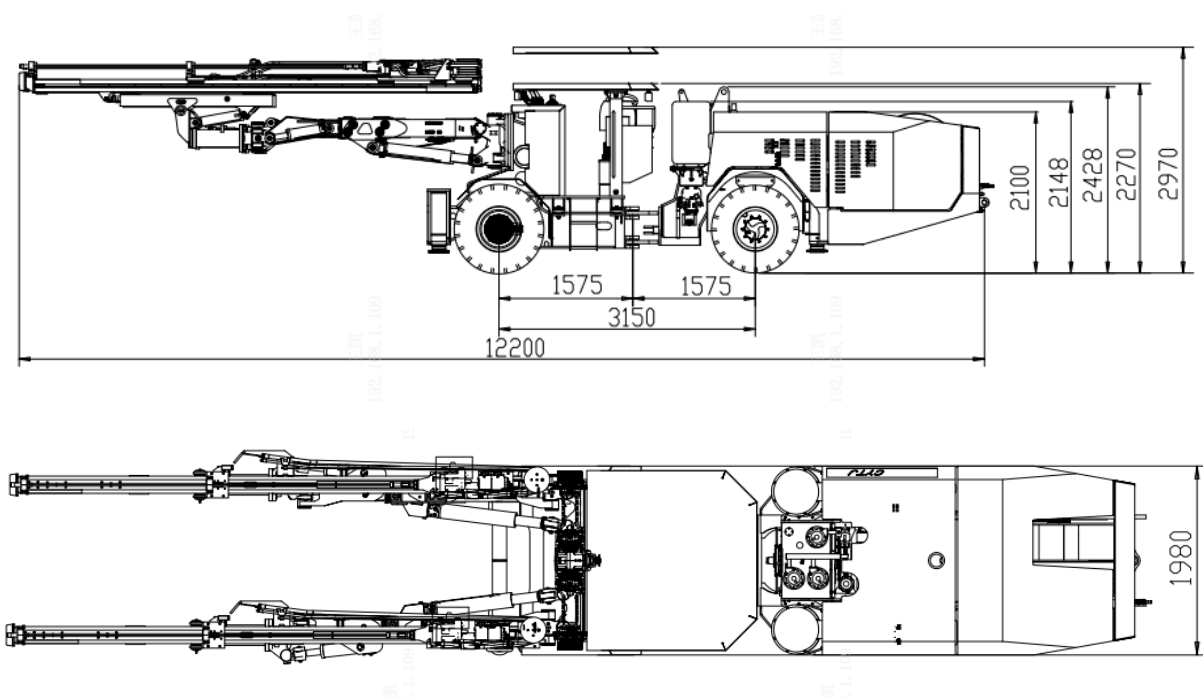

Coverage area, cross sections up to 45 m²

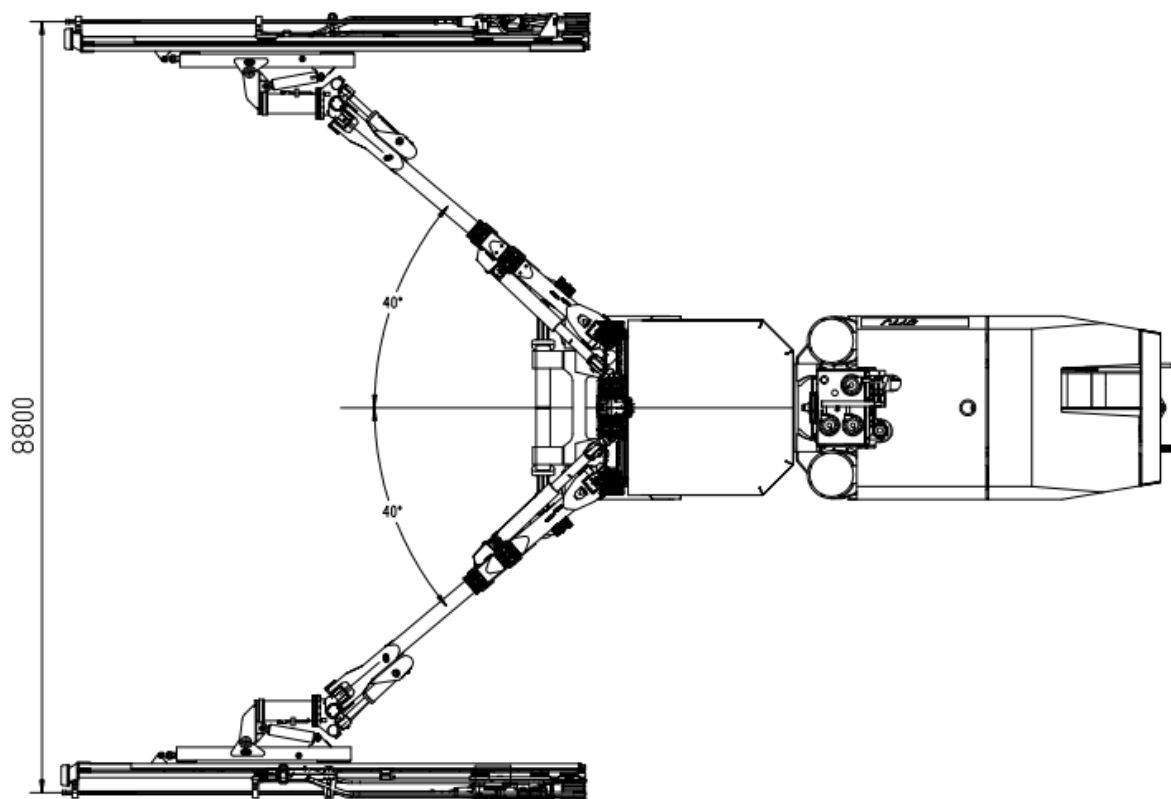
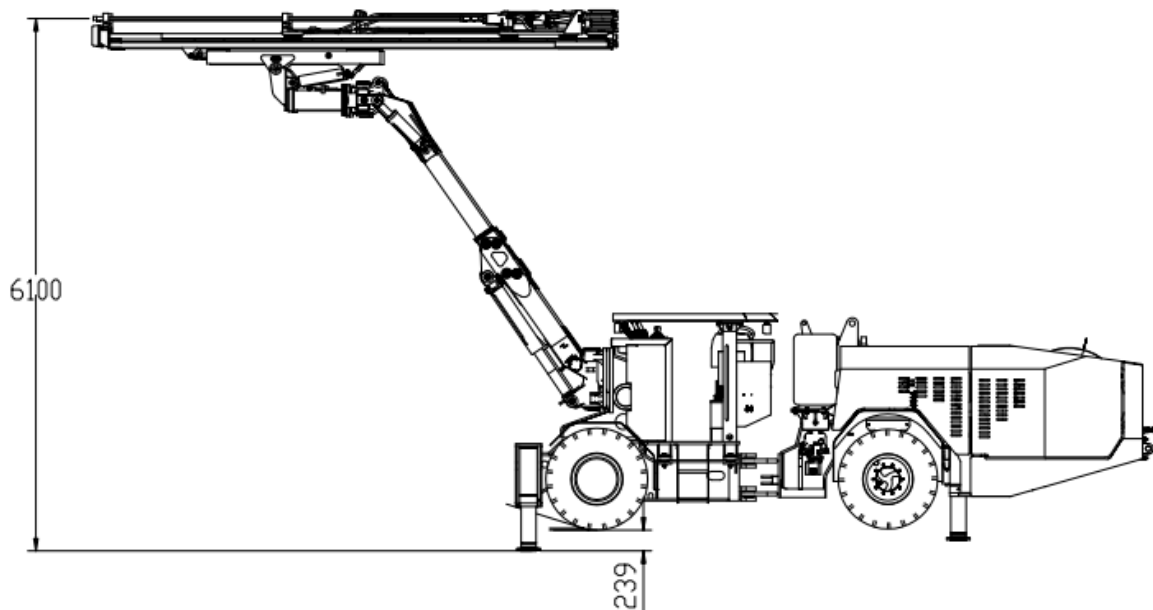

Turning Radius

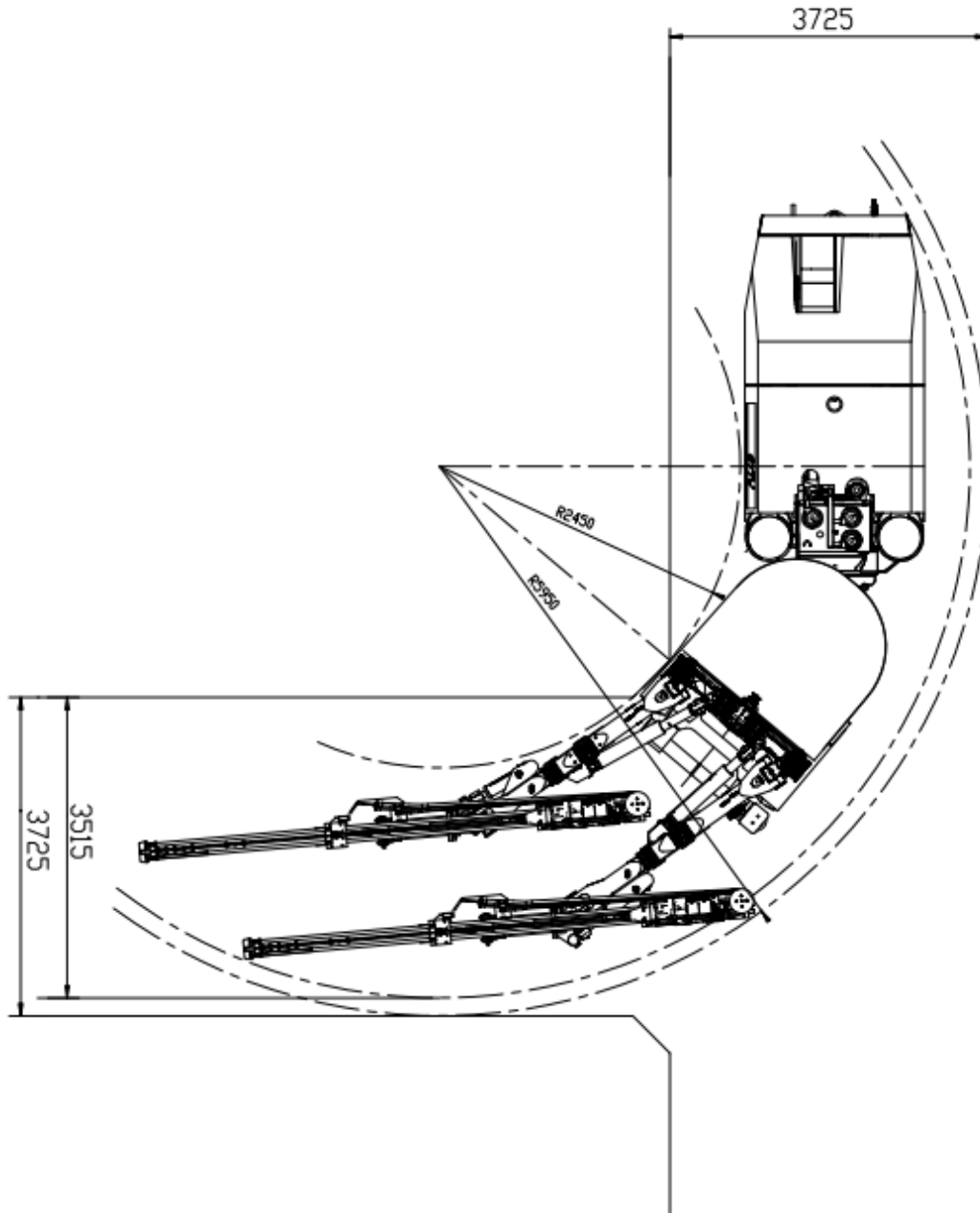

PHOTO





Main components of CYTJ45-2 Hydraulic Drilling Jumbo

No.	Item	Model	Manufacturer or Brand
1)	Hydraulic drifter	18U	Epiroc
2)	Main pump		DANFOSS
3)	Valve spool		SUN
4)	Electric motor	55kw	WEG, China
5)	Diesel engine		Cummins,
6)	Tyre	12.00-20	Tianjin international
7)	Water pump	CDL8-16	Nanfang, China
8)	Air compressor	1.2 m ³ /min	China make
9)	Hose		Baili China
10)	Cable	3X50+1X10 mm ²	China
11)	Steel rod and bit		LHS, China
12)	Axle		Fenyi, China

