

LWLX-80/45L Crawler Mucking Loader



Specifications

1. Fast, Efficient and Safety
2. Flexible Operation
3. Great Power
4. Clear Completely
5. Underground mining

Range of application

The mucking loader is mainly used in coal mines, metal mines, hydropower tunnels and other underground projects. The company has developed different kinds of loaders many times and updated them to adapt to different working conditions including section from 2.0 x 2.0 m to 9 x 9 m (Height x Width), slope within 33°.

Main characteristics

1. The mucking loader adopts Electrohydraulic control system with reduced-voltage start Suitable for long tunnel projects.
2. Main movements controlled by pilot valves, Easily operated and stable.
3. 30% of the configurations are imported. Oil will be Multistep filtered with air cooling radiator.
4. Load rocks completely without labor work.
5. Convey rocks with chain -scraper, stable and high efficiency.
6. Semi-enclosed assembling, easy to maintain.

Small-size Crawler Mucking Loader For Big Slope ≤ 30 degrees

Main Overall Dimension	LWLX-80/45L
Crawler contacting ground length	2407mm
Crawler inner width	941 mm (variable)
Crawler plate width	340/450 mm
Ground clearance	≥ 330 mm (variable)
Conveyor inner width	580 mm
Dimensions during transport	(9000±50)×(1800±50)×(2050±50) mm

Your Ideal Mining Solutions for Underground Mining, Tunneling, Shaft sinking from China!

Dimensions during operating	(9906±50)×(4800±50)×(2700±50) mm
-----------------------------	----------------------------------

Working Range

		LWLX-80/45L	
	Item	Standard arm	Short arm (selective)
A	Digging width	4800~5300 mm	3200 mm
B	Digging distance(from dozer blade)	1820~1970 mm	1530 mm
C	Digging height	2650~2940 mm	2300 mm
D	Digging depth below ground level	645 mm	320 mm
E	Dumping height	1950 mm (variable)	
F	Dumping distance	1905 mm (variable)	
G	Max. boom angle	±5°	
H	Adaptive tunnel dimension (Width × Height)	≥2.5×2.5 m	

Functional Parameters

Model	LWLX-80/45L
Loading ability	80 m ³ /h
General power for electric motor	45 kw
Engine for crawling	YCD4R23T8-65
Engine power	48KW/ 65HP
Weight	9550±100 kg
Traveling speed	1.01±0.07 % km/h
Scraper chain	Single chain single motor
Adaptive tunnel slope	≤30°
Minimum turning radius	≤3.5m
Ground pressure	≤0.07 Mpa
Steering	Hydraulic
Speed of scraper chain	48±2 m/min
Volume of hydraulic tank	220L
Rated working pressure	20 MPa
Check valve release pressure	21 MPa
Hydraulic pump	Plunger pump×2 + gear pump×2
Walking hydraulic motor	Radial plunger motor×2
Conveyor hydraulic motor	Radial plunger motor×1

Your Ideal Mining Solutions for Underground Mining, Tunneling, Shaft sinking from China!

Dimensions of the mucking loader:

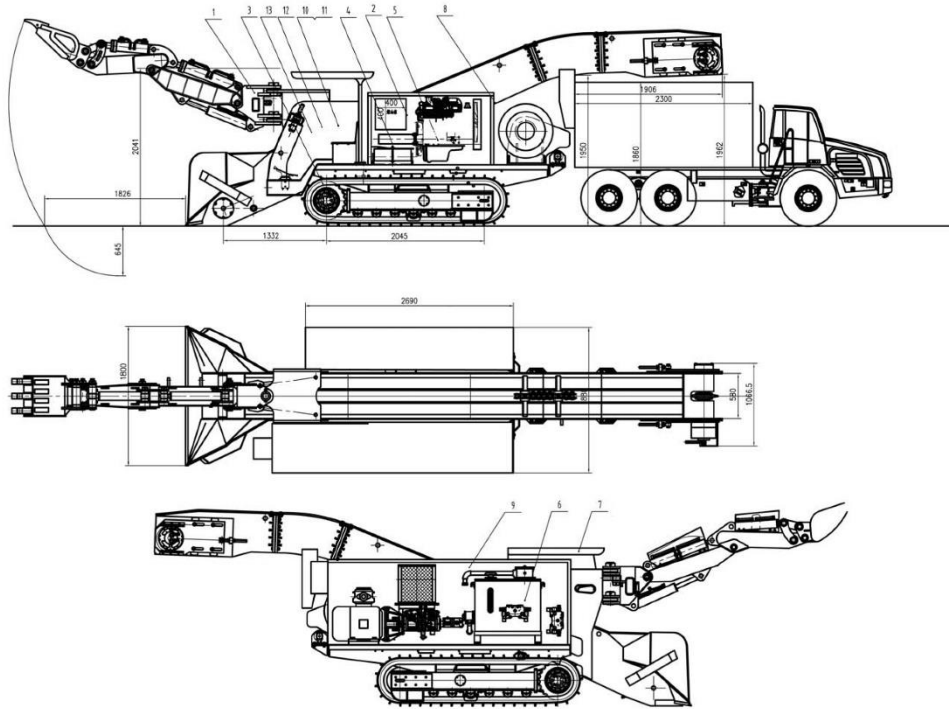

Main components and brand

Standard engine brand: YTO, Yuchai, Yunnei.

Options: Yanmar (47KW), Deutz engine D914L04 (58KW).

Electric motor: ABB/45KW

Piston pump: BPA64DT

Gear pump: Saur Danfoss | Parker

Travelling motor: IKY34A-9100D2402

Multiple directional valve: ZL20H



Options

- ✓ Engine compartment fire suppression system;
- ✓ Quick release device

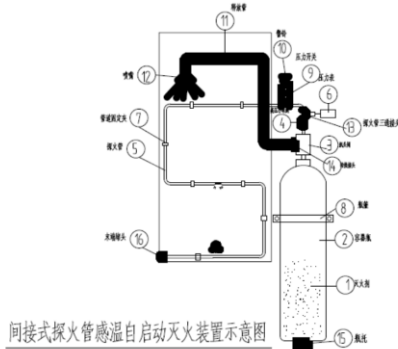

- ✓ Lincoln Automatic lubrication system
- ✓ Doosan rock hammer



Doosan Rock Hammer HB04S specifications

Model	HB04		
Net weight	silence type (h)	kg	155
	triangle (s)	kg	158
	erect (t)	kg	158
Hydraulic pressure	bar	88~117	
Hydraulic oil flow	liter/min	25~50	
Impact frequency	bpm	600~1,100	
Chisel diameter	m	53	
Suitable mucking loader weight	ton	2.5~4.5	

❖ AFTER-SALE SERVICE

Maximize productivity time and reduce costs for the clients.

- ✓ 1 year | 2000 engine hours warranty after commissioning;
- ✓ Rolling spare parts stock in the owner's country at supplier's cost;
- ✓ Free training in supplier's workshop;
- ✓ Free on-line training for the buyer's operators;
- ✓ 24-hours on-line support.

❖ Delivery reference:







